

**ECM**  
MANUFACTURE



Commercial Line

## ECM Manufacture

Excellent craftsmanship!

Perfection is our ambition and our motivation: We manufacture high-quality espresso machines and espresso grinders with vision and passion - quality products for unique espresso enjoyment.

Our highly motivated team, inspired by the fascinating world of espresso, unites German engineering with elegant Italian styling - an ideal synergy. Reinforced by solide technology, the highest quality standards and exquisite handcrafted design.

Our goal is to equip you optimally, both with high-quality espresso machines and espresso grinders, and also with professional accessories to prepare the perfect espresso.





Our team of coffee-enthusiastic  
employees in Germany  
craft our products by hand.

# ECM espresso machines

Compact. Powerful. Professional.

Innovative technology and precise production: ECM espresso machines –high-quality products in elegant design for the commercial use.

Due to the special heat exchanger system, the elaborate ECM brewing group and the innovative valve technology ECM espresso machines meet the most professional demands – for every application.

Perfectly thought through: heat exchanger espresso machines have two separate water circuit systems, which allow for the simultaneous preparation of both espresso and steamed milk. Fresh water from the water tank, or direct water supply, is always used for the preparation of espresso. The optimal temperature stability is guaranteed by the thermosyphon system, which heats the brew group by permanently circulating hot water.

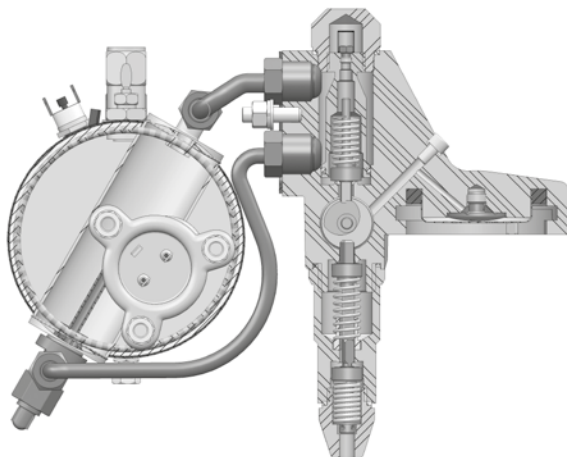



Elektronika Profi Due



ELEKTRONIKA PROFI DUE

Item-No. CM100019-00

OVERVIEW



FEATURES

- ① HX-machine
- ② Built-in rotary pump
- ③ ECM brew groups with innovative stainless steel bell
- ④ Quick-steam and hot-water lever valves
- ⑤ ECM portafilters
- ⑥ Water tank volume approx. 3 l
- ⑦ Automatic group cleaning programm
- ⑧ Service friendly: easy to open by loosening 4 screws
- ⑨ Automatic dosing through control panel
- Boiler volume approx. 4 l
- Commercial pressure control
- Water tank and fixed water connection
- Handmade in Germany

SIZES

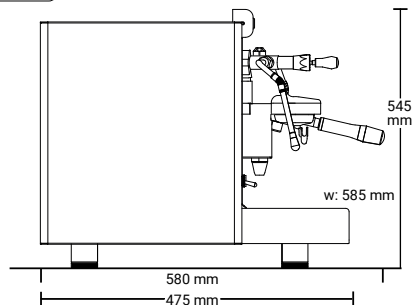

⑨ CONTROL PANEL



- 4 different coffee volumes possible.
- Optional: manual coffee dosing

LIFE IS BUDDY



Compact HX-2 PID



COMPACT HX-2 PID

Item-No. CM100018-00

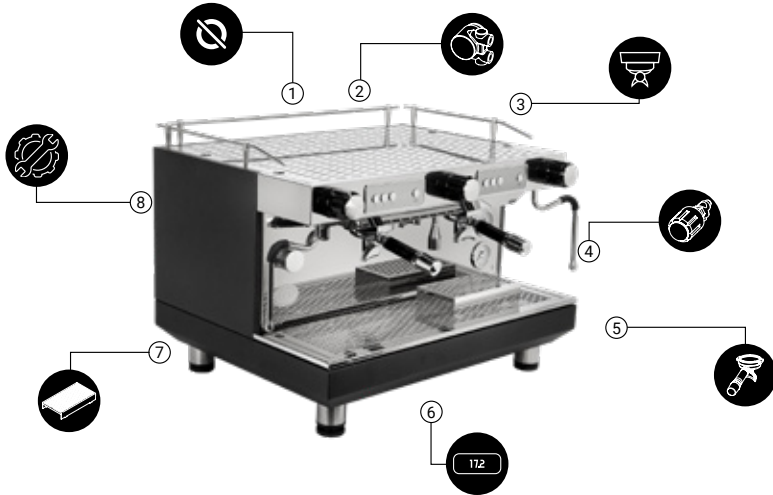

**FEATURES**

- 1 HX-machine
- 2 Built-in rotary pump
- 3 Ring brew groups
- 4 Quick-opening steam and hot water rotary valves
- 5 ECM portafilters
- 6 Shot counter to indicate the coffee brewing time
- 7 Drip-grids to raise cups
- 8 Service friendly: easy to open by loosening 4 screws
- 9 Programmable dosing
- Boiler volume approx. 9 l
- Automatic brew group cleaning programm
- Connectible, electronically controlled preinfusion
- Handmade in Germany

**SIZES**

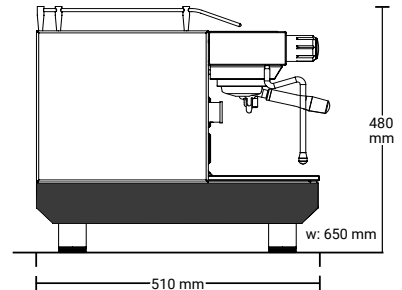

**9 CONTROL PANEL**



- Programmable dosing of 3 coffee buttons
- 1 manual dosing button

COMPACT HX-2 PID

Item-No. CM100018-00



BARISTA A2 PID



BARISTA A2 PID  
Item-No. CM100015-00

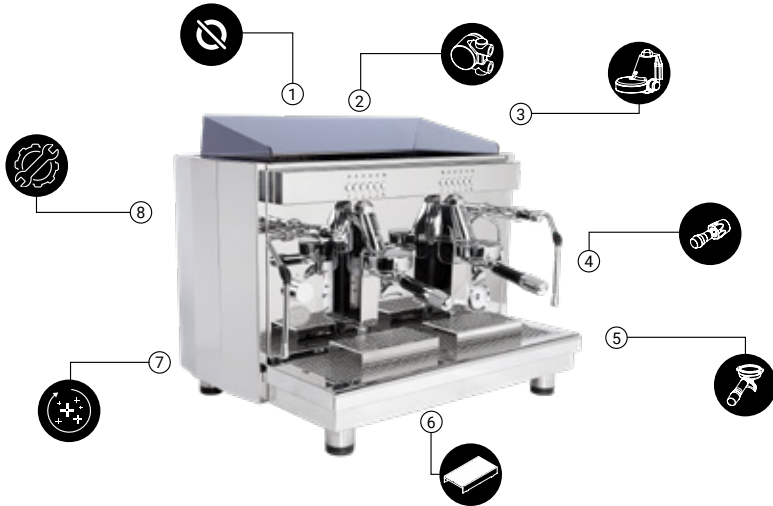

**FEATURES**

- ① HX-machine
- ② Built-in rotary pump
- ③ ECM brew groups with innovative stainless steel bell
- ④ Quick-steam and hot-water lever valves
- ⑤ ECM portafilters
- ⑥ Drip-grids to raise cups
- ⑦ Automatic brew group cleaning program
- ⑧ Service friendly: easy to open by loosening 4 screws
- ⑨ Programmable dosing
- Boiler volume approx. 14 l
- Connectible, electronically controlled preinfusion
- Dual pump and boiler gauge
- Handmade in Germany

**SIZES**

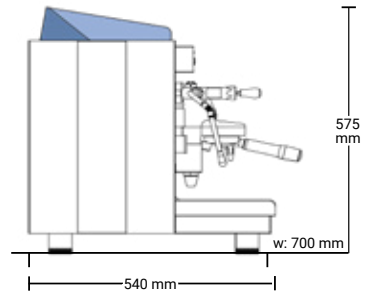

⑨ **CONTROL PANEL**



- Programmable dosing of 4 coffee buttons
- 1 manual dosing button

BARISTA A2 PID

Item-No. CM100015-00



GRINDERS



#### FEATURES

- Easy programming of the timer for 1 or 2 portions
- Switch for manual grinding option
- Display of the grinding portions
- Stepless adjustment of the grind
- Stepless height-adjustable portafilter bracket
- Hands-free use possible
- Bean hopper volume approx. 500 g (optional 1.000 g)
- Housing in polished stainless steel or powder-coated
- Motor performance: 450 W
- Weight: 9.8 kg
- Handmade in Germany

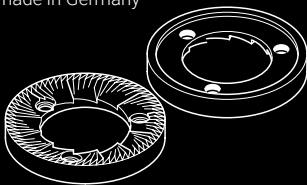

64 mm

Titanium-coated burrs



#### V-Titan

Polished stainless steel - Item-No. GR100006-00

Powder-coated - Item-No. GR100006-01



**FEATURES**

- Easy programming of the timer for 1 or 2 portions
- Display of the grinding portions
- Stepless adjustment of the grind
- Bean hopper volume approx. 500 g (optional 1.000 g)
- Housing in polished stainless steel or powder-coated
- Motor performance: 450 Watts
- Weight: 6.8 kg
- Handmade in Germany

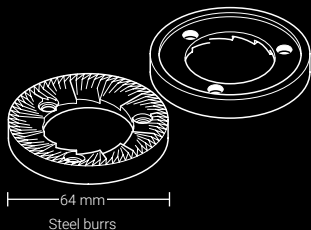

**S-Automatik 64**

Polished stainless steel - Item-No. GR100005-00  
Powder-coated - Item-No. GR100005-01



**FEATURES**

- Programmable portions
- 3 operating modes
- Stepless adjustment of the grind
- Bean hopper volume approx. 250 g
- Free-handed use possible
- Motor performance: 235 W
- Bean hopper volume approx. 500 g (optional 1.000 g)
- Weight: 5.26 kg
- Handmade in Germany

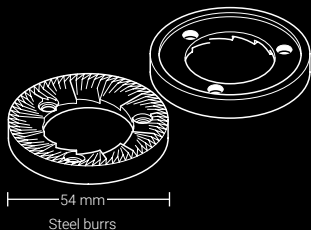

## Product overview espresso machines



Model	Elektronika Profi Due	Compact HX-2 PID	Barista A2 PID
Item-No.	CM100019-00	CM100018-00	CM100015-00
System	Heat exchanger	Heat exchanger	Heat exchanger
ECM brew groups	•		•
Ring brew groups		•	
Pump type	Rotary	Rotary	Rotary
Preinfusion		programmable	on/off
Water tank	approx. 3 l		
Direct Water Connection	•	•	•
Switchable water tank / fixed water supply	•		
Boiler volume	approx. 4 l	approx. 9 l	approx. 14 l
Boiler material	Copper	Stainless steel	Copper
Boiler (1) / Pump (2) pressure gauge	1 + 2	1 + 2	1 + 2 (Dual gauge)
PID control		•	•
Display		•	•
Automatic dosing	4 progammable	3 progammable	4 progammable
Manual coffee dosing	•	•	•
Rotary valve technology		•	
Lever valve technology	•		•
Large cup warming tray	•	•	•
Number ECM portafilters	2	3	3
Drip-grid to raise cups		2	2
Heat-up phase	25-30 min	25-30 min	25-30 min
Performance	2500 W	3000 W	4000 W
Voltage	230 V*	3 phases, 230 V*	3 phases, 230 V*
Weight	42 kg	58 kg	72.5 kg
Dimensions w x d x h (without portafilter)	585 x 475 x 445 mm	650 x 510 x 480 mm	730 x 537 x 520 mm
Dimensions boxed	670 x 520 x 500 mm	860 x 660 x 750 mm	860 x 660 x 750 mm

\*Other voltages on request

## Product overview espresso grinders



Model	V-Titan 64	S-Automatik 64	C-Automatik 54
Grinding mechanism	aluminium	aluminium	aluminium
Diameter burrs	64 mm	64 mm	54 mm
Material burrs	titanium coated	steel	steel
Stainless steel grinding adjustment	■	upgradable	
Motor performance	450 W	450 W	235 W
Bean hopper capacity	500 g optional 1000 g	500 g optional 1000 g	250 g
Display	■	■	■
Dosing	programmable	programmable	programmable
Grind setting	stepless	stepless	stepless
Quantity counter display	■	■	■
Height-adjustable portafilter rest	■		■
Stainless steel housing	polished or powder-coated	polished or powder-coated	polished
Weight	9.8 kg	6.9 kg	5.3 kg
Dimensions w x d x h mm	200 x 260 x 445	145 x 200 x 415	130 x 170 x 357
Item number	GR100006-00 GR100006-01	GR100005-00 GR100005-01	GR100002-00

You will find grinders with only manual dosing function on our website <https://www.ecm.de/en/>

*we live espresso*

**ECM**  
MANUFACTURE

ECM® Espresso Coffee Machines Manufacture GmbH  
Industriestraße 57-61, 69245 Bammental  
Telefon +49 6223-9255-0  
E-Mail [info@ecm.de](mailto:info@ecm.de)

[www.ecm.de](http://www.ecm.de)

